

Natural Refrigerants and Tesco

Andy Campbell B.Eng (Hons)
M.Inst.R.



**TEKNOLOGISK
INSTITUT**

TESCO
REFRIGERATION CoE

Format of Presentation

- Current Situation in the UK
- Our Reasons/ Drivers for looking at CO₂
- Technology level available in the UK
- Future plans and how you can help

Current Situation in the UK

UK CO₂ PROGRESSION IN SUPERMARKETS

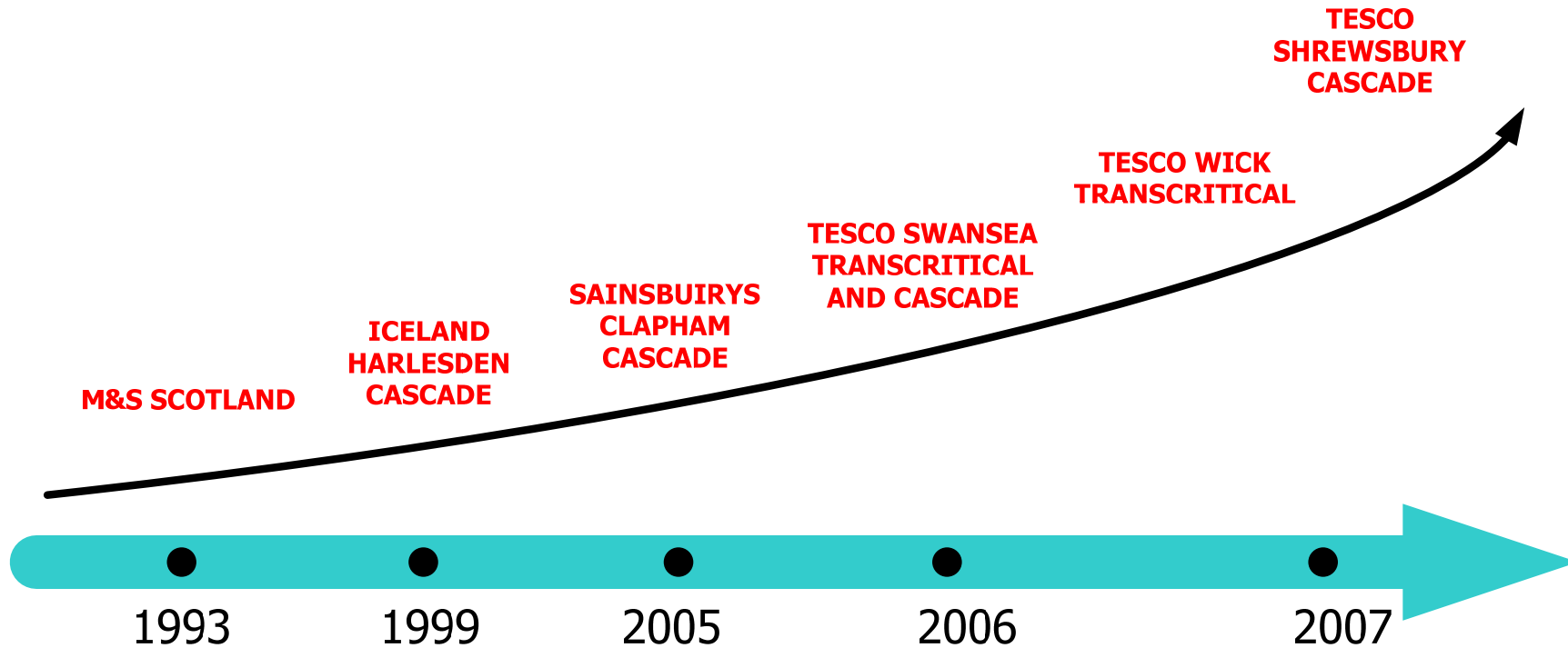

Installed Capacity

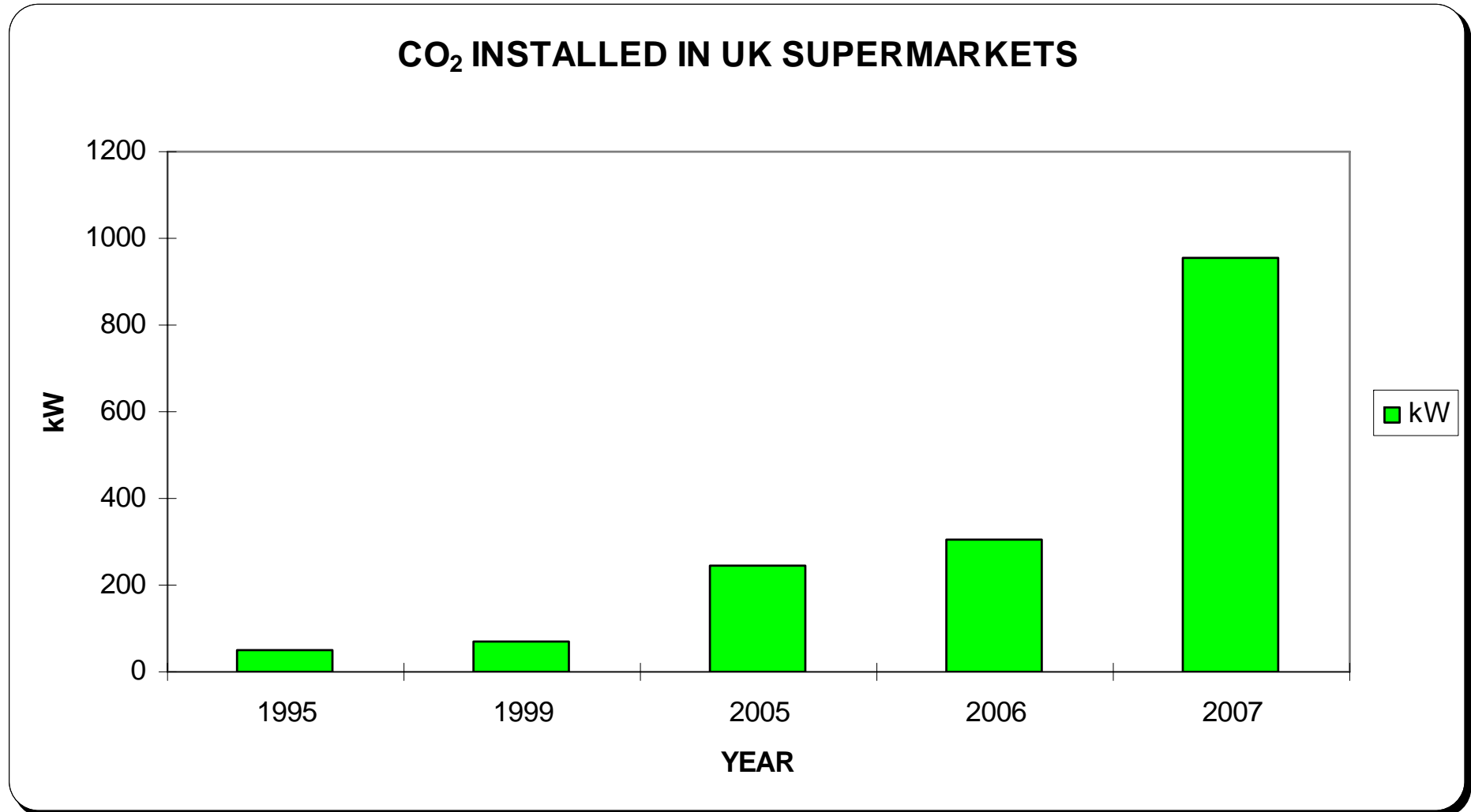

UK, DENMARK COMPARISON

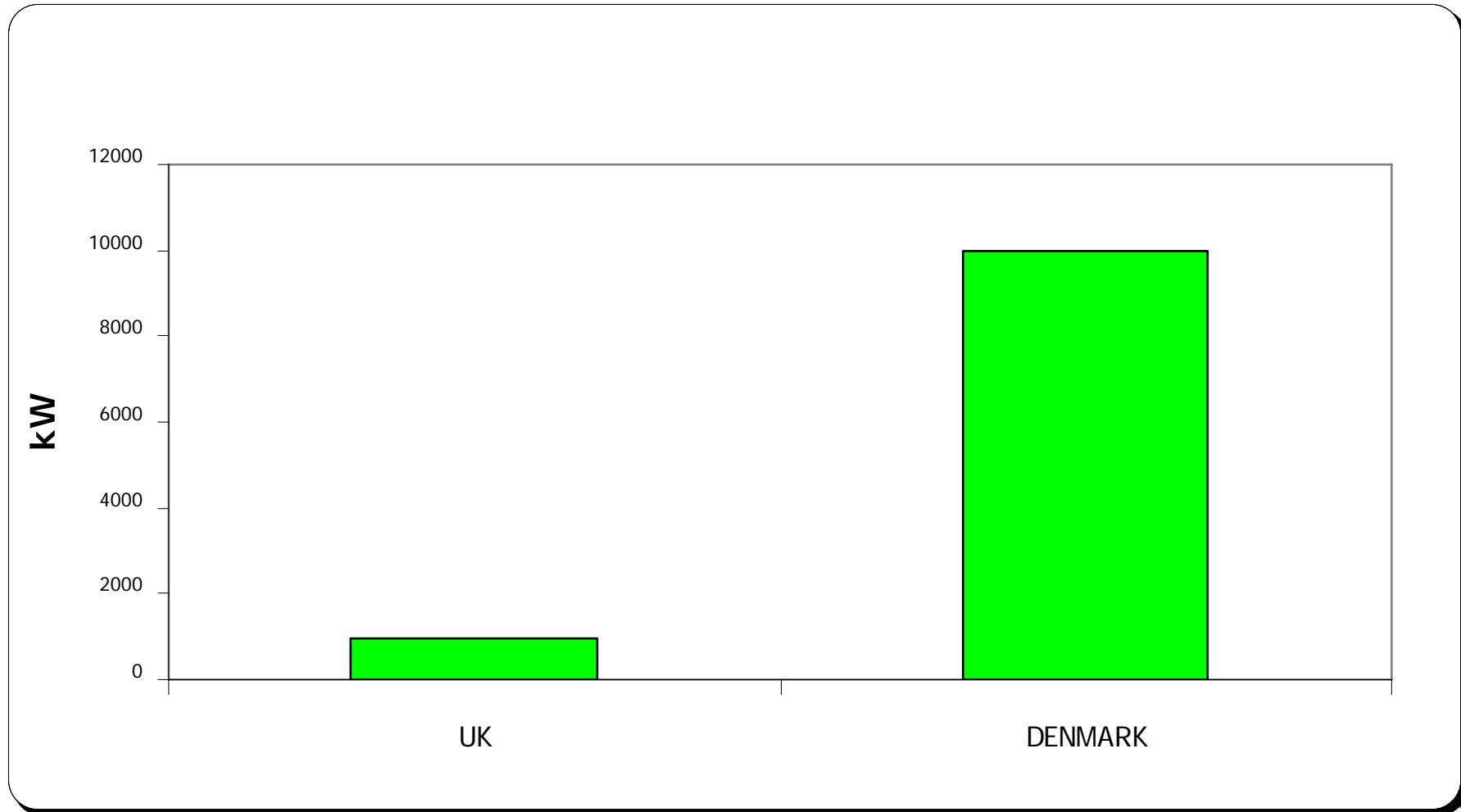

Population

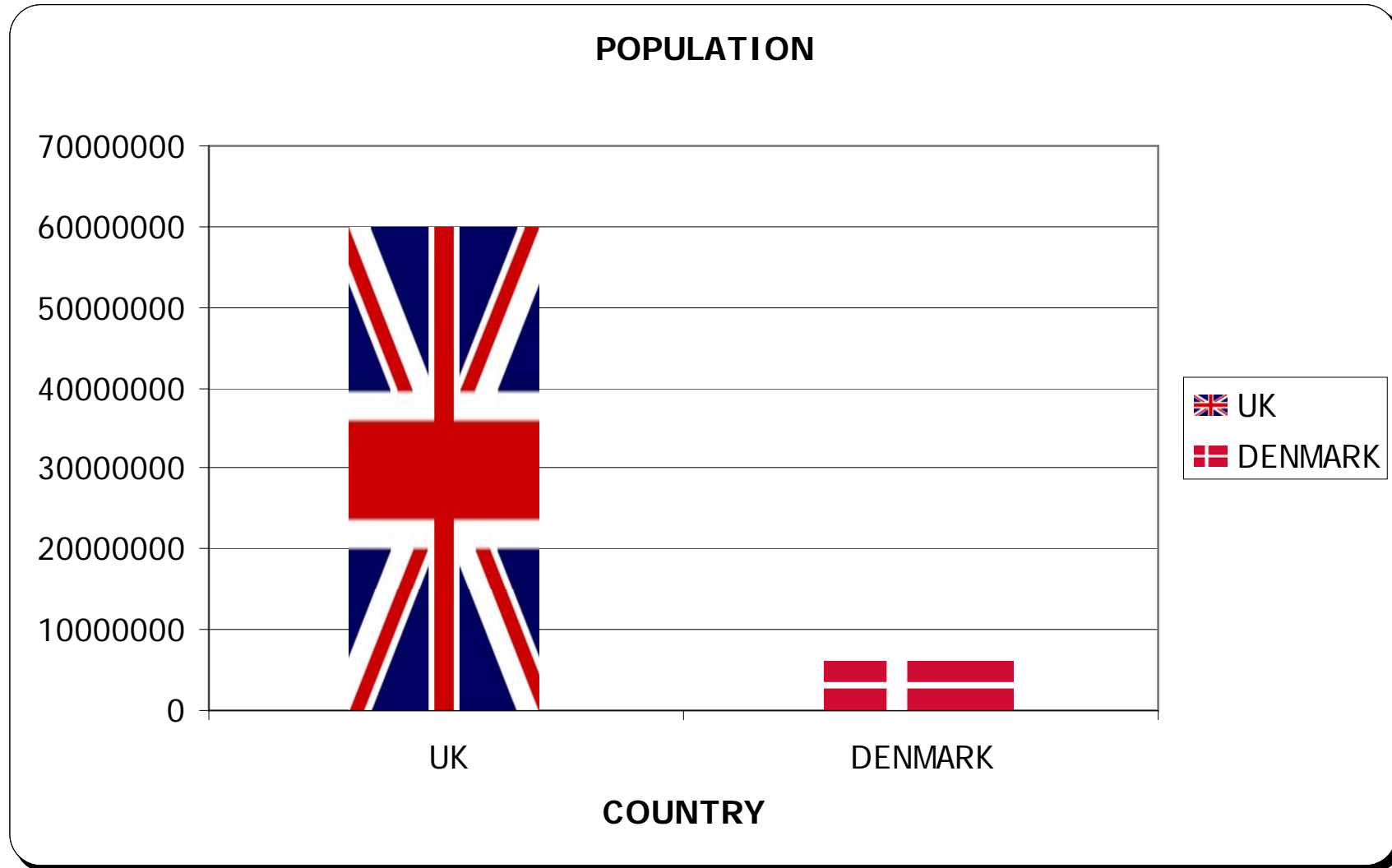

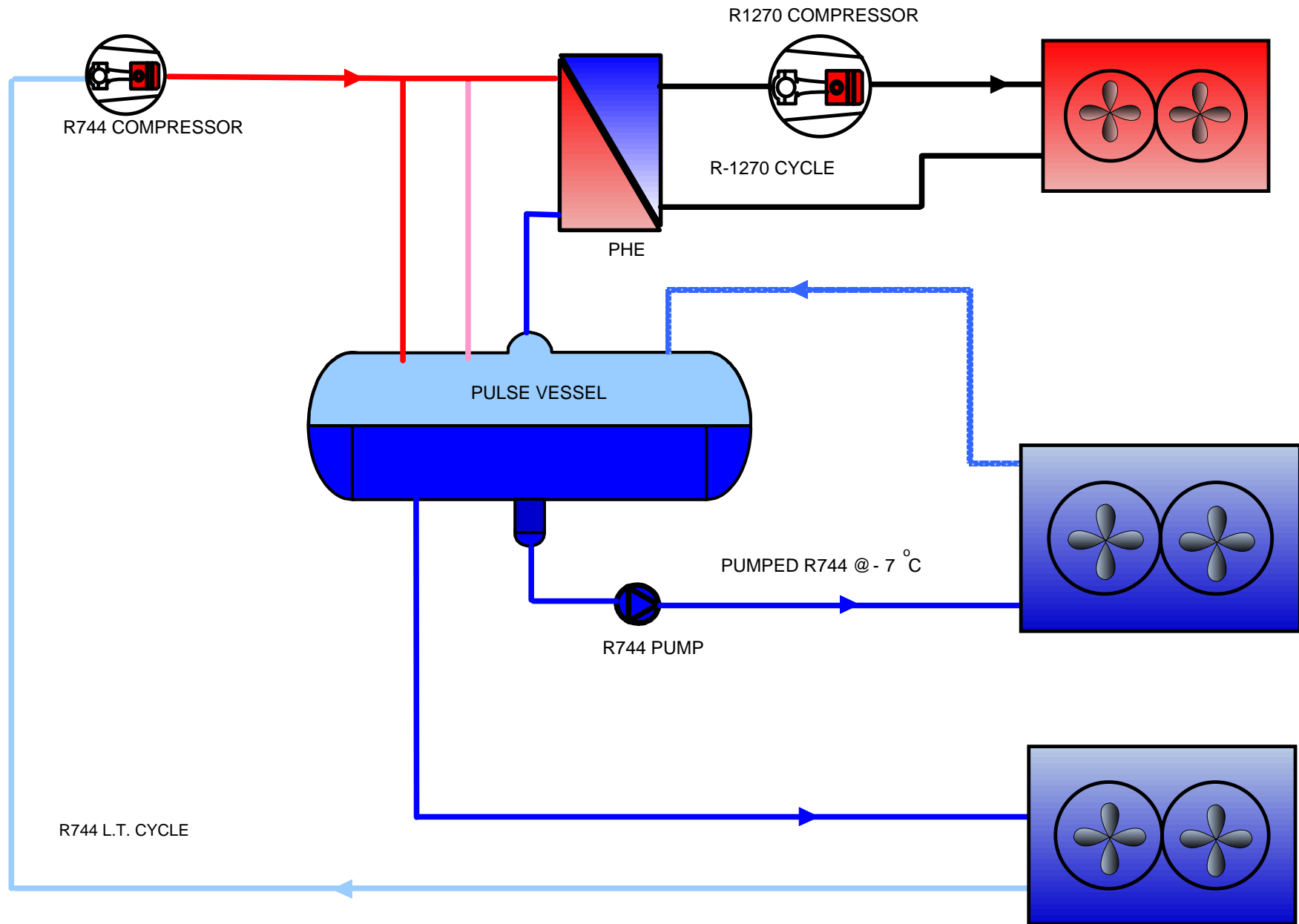

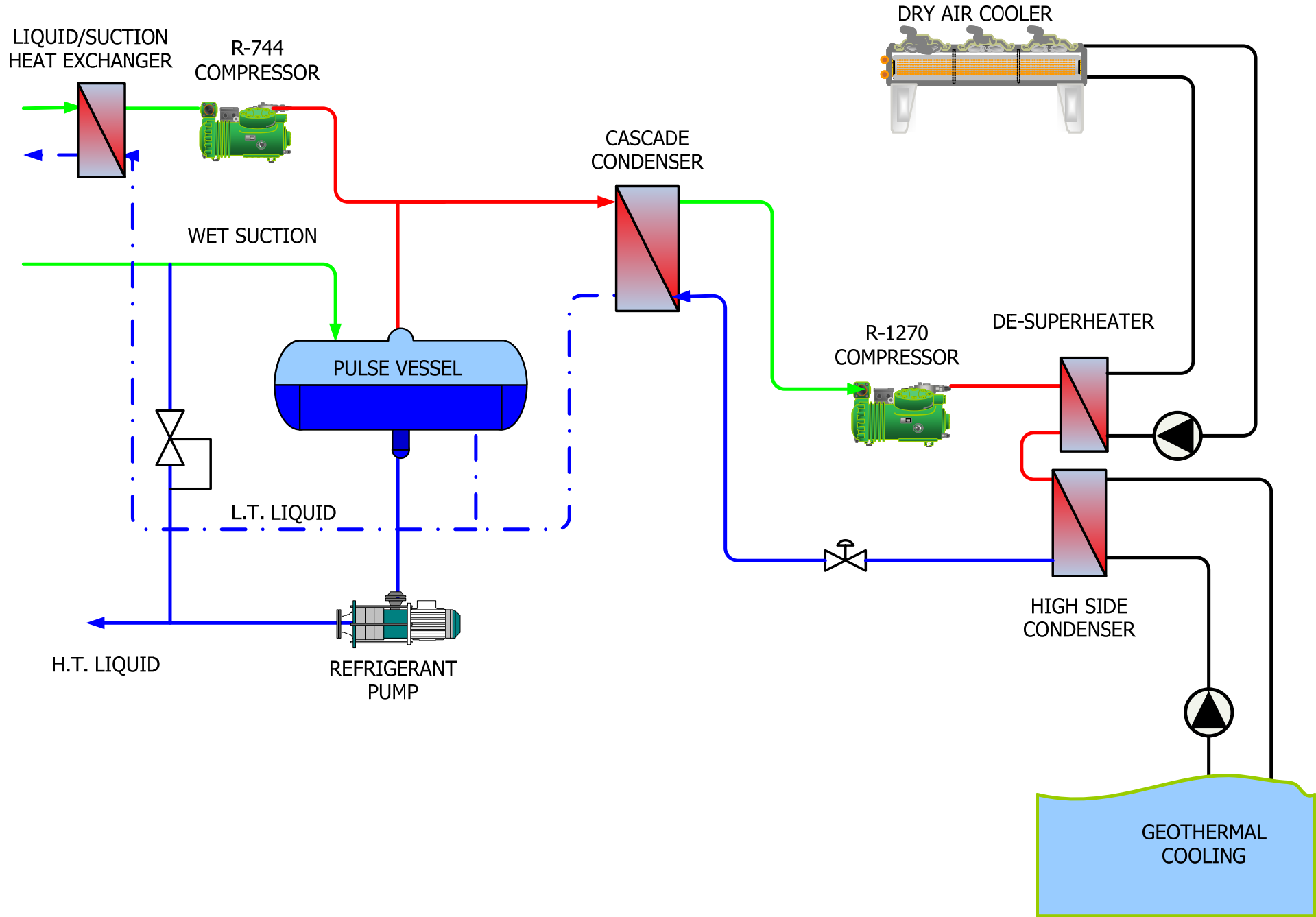

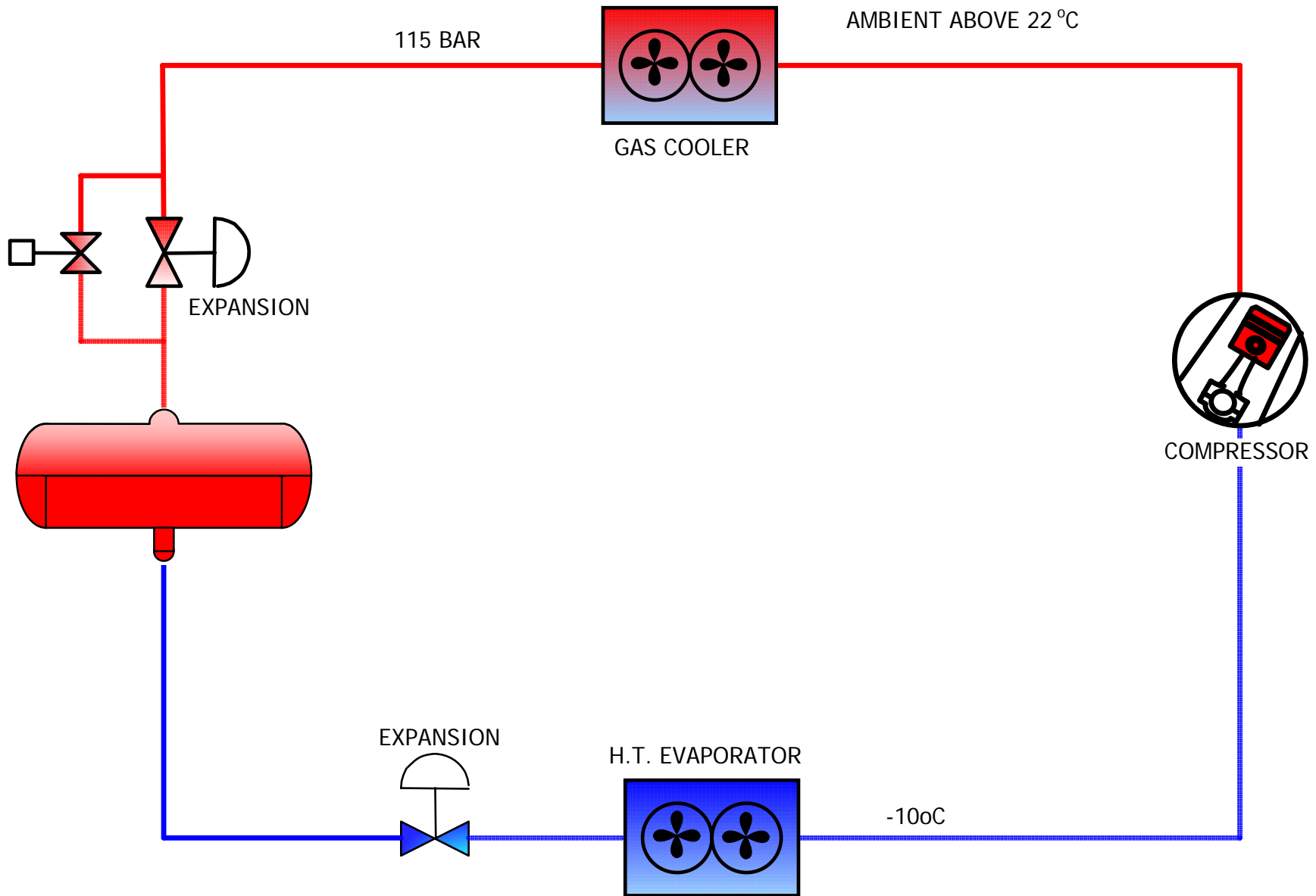

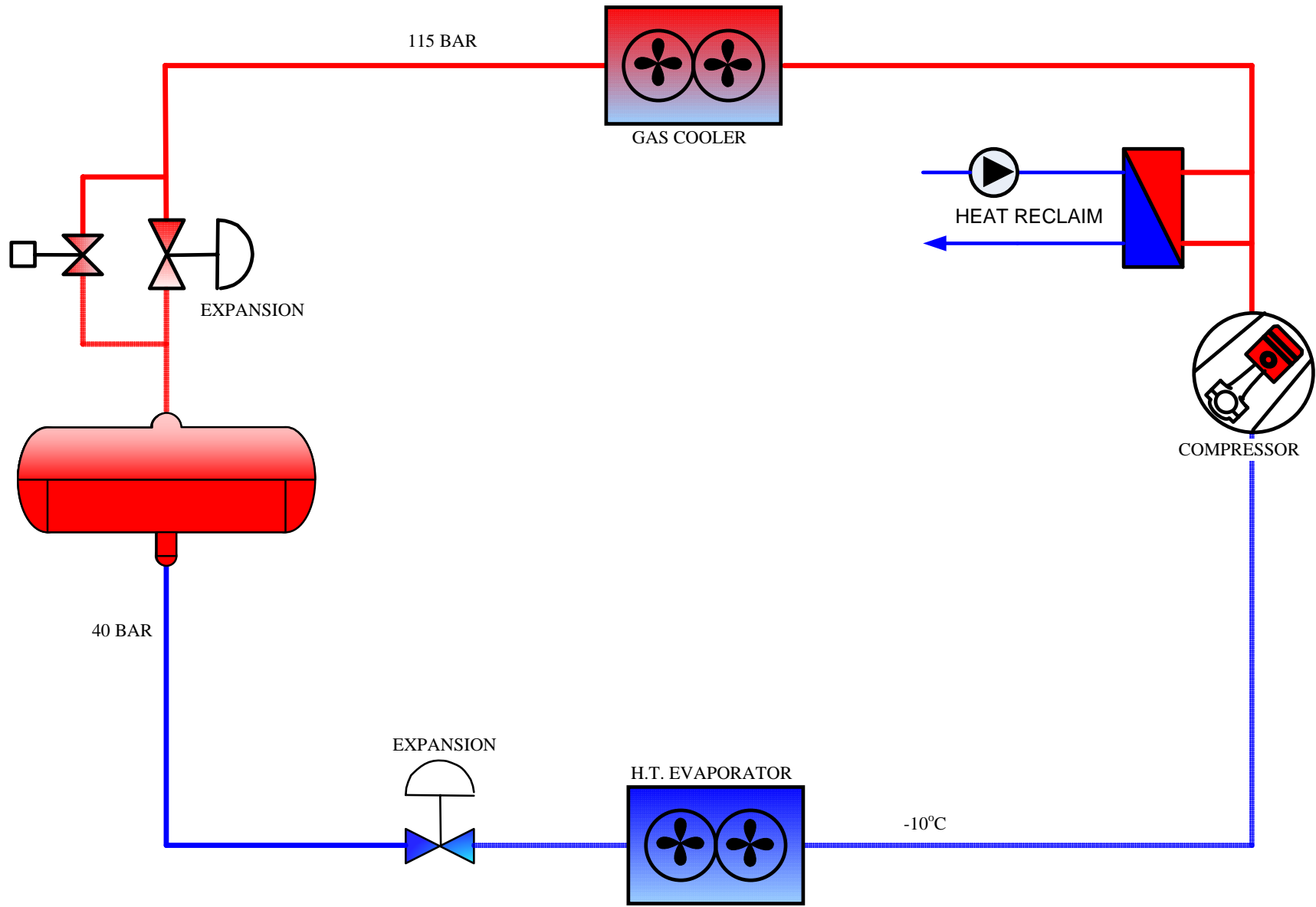





Reason/Drivers

Drivers

Energy and environment are now a public concern	
50% Reduction in Carbon footprint by 2020	
No more refrigerant change outs	
F-Gas Regulations	
HFC Legislation	

OUR CARBON REDUCTION TARGET

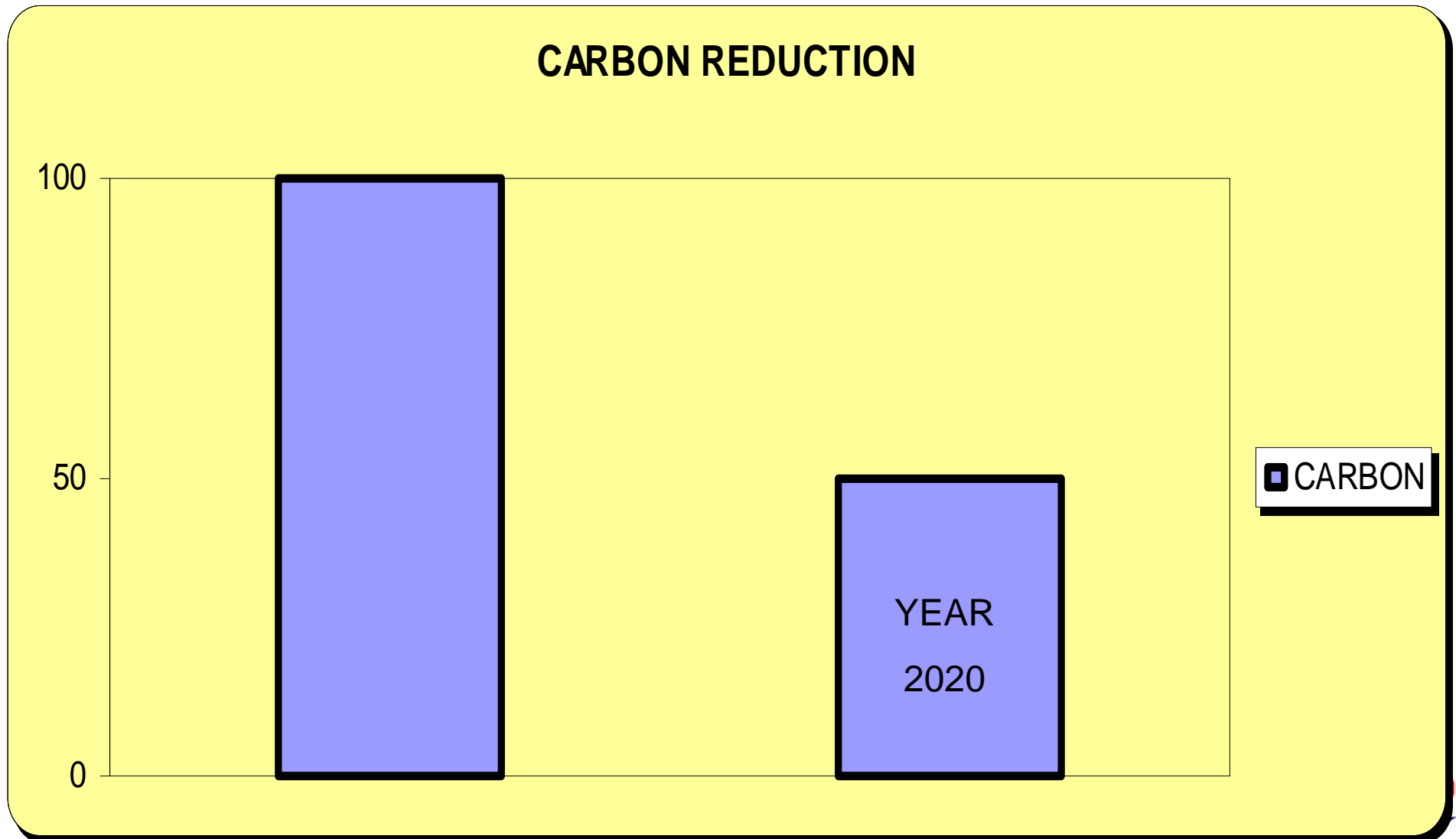

Carbon Footprint

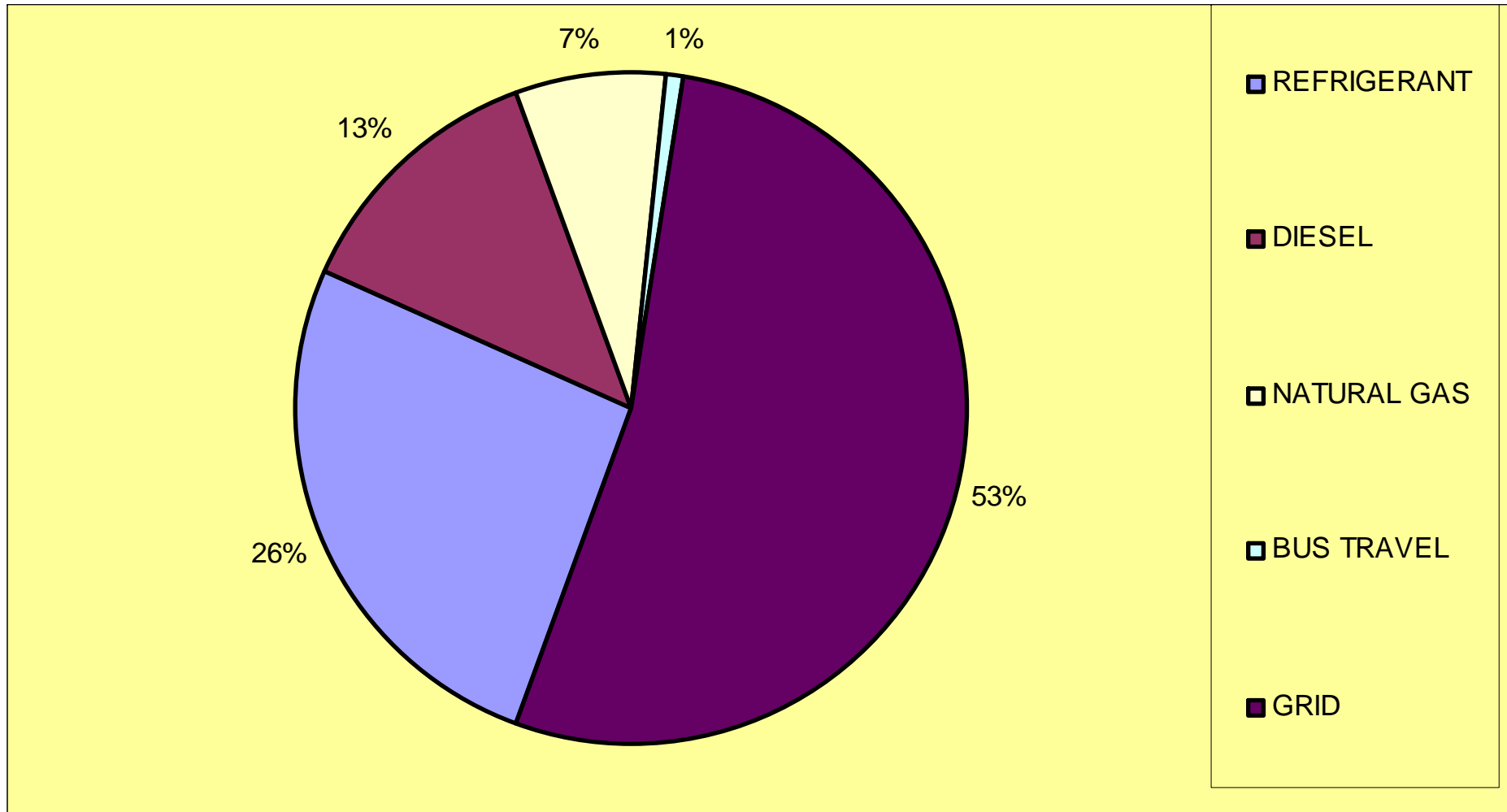

Carbon Footprint

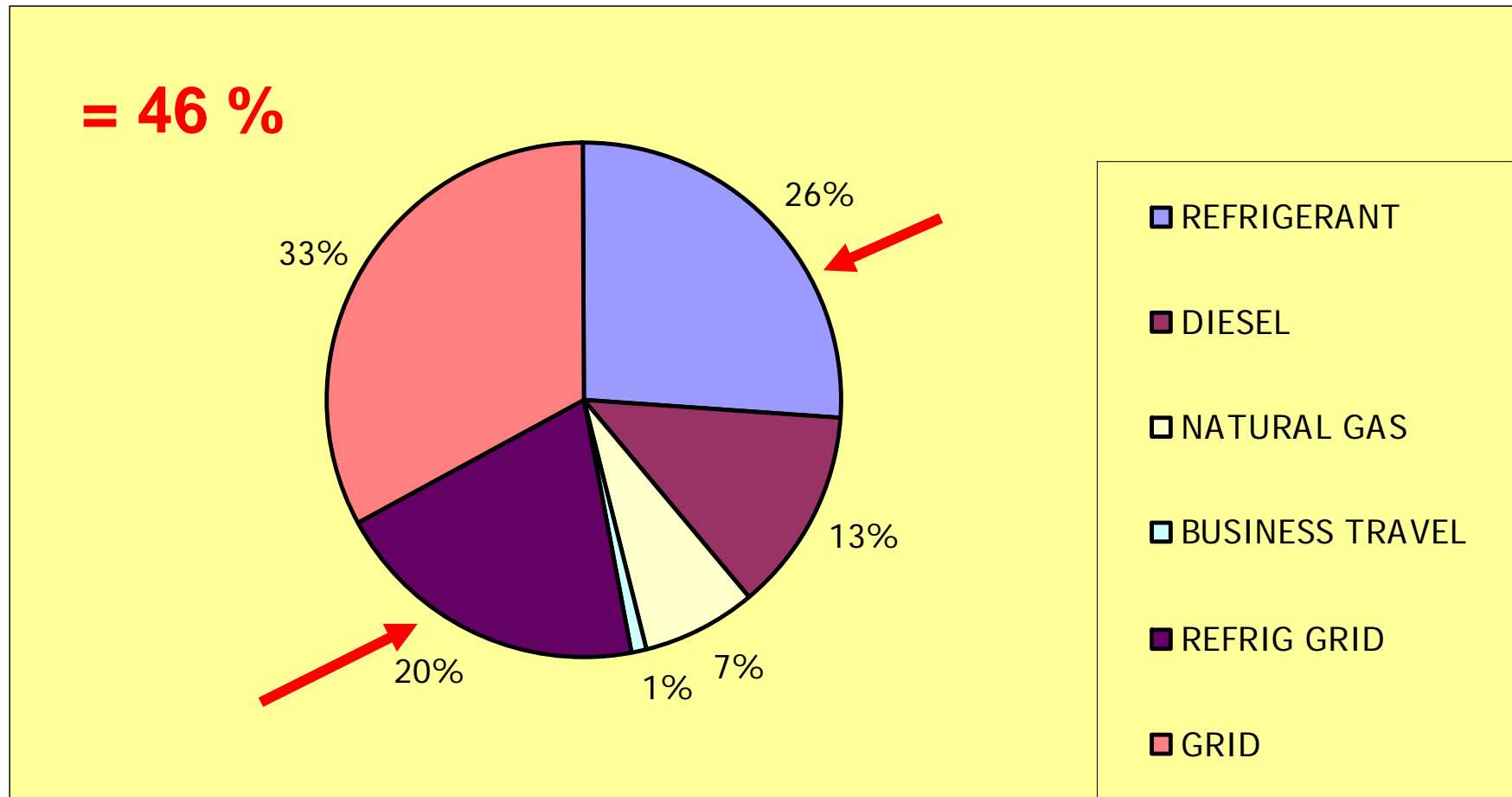

Technology level available in the UK

Refrigeration Trade in the UK

- Traditional Apprenticeship Schemes Gone
- Reducing Numbers Entering the industry
- Less and Less bespoke designs
- No Licensing of Trade
- Willingness to try



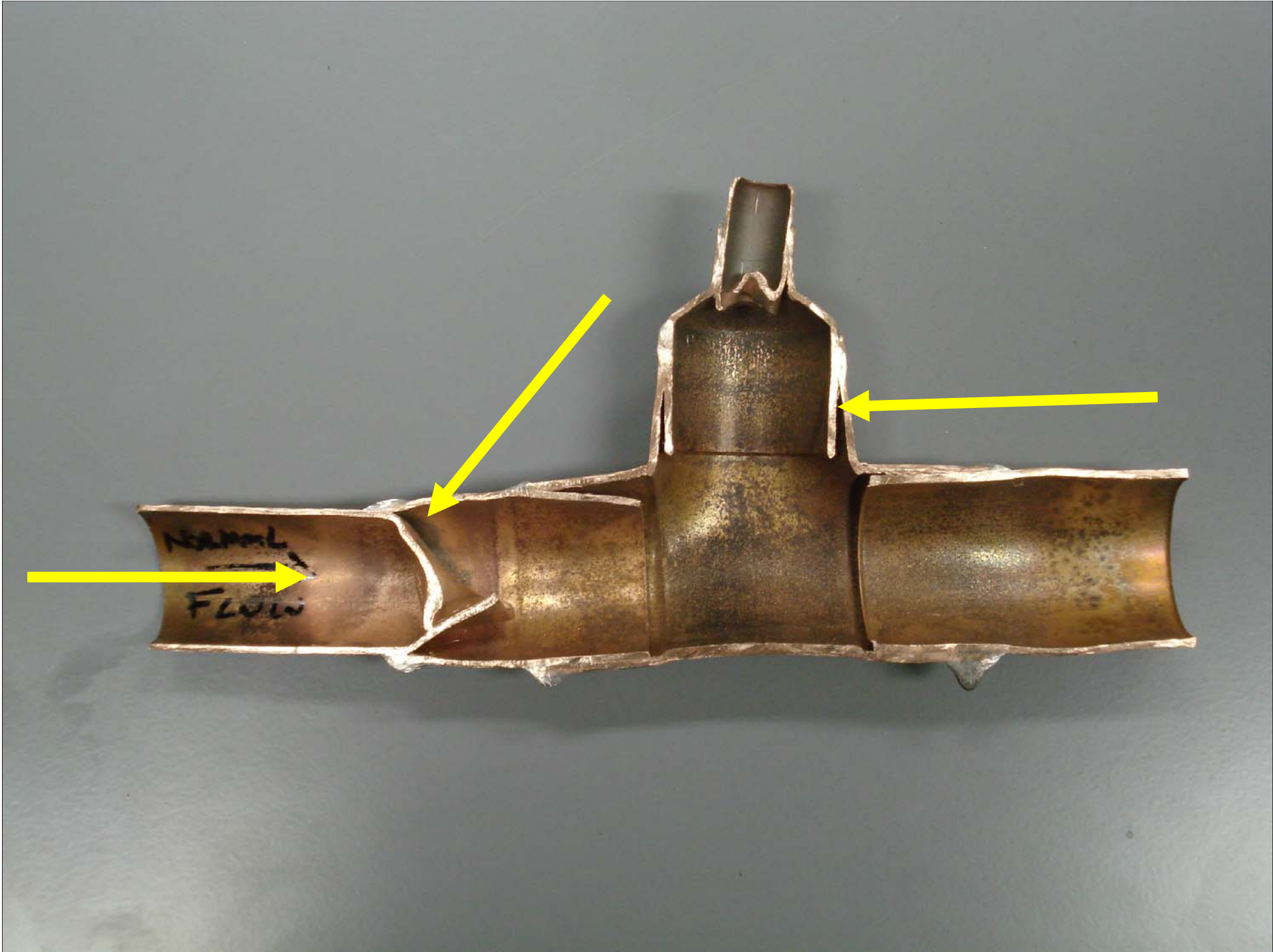

Future plans and how you can help

Future plans and how you can help

- We plan to develop modular solutions with the capability of suiting each store size and requirements

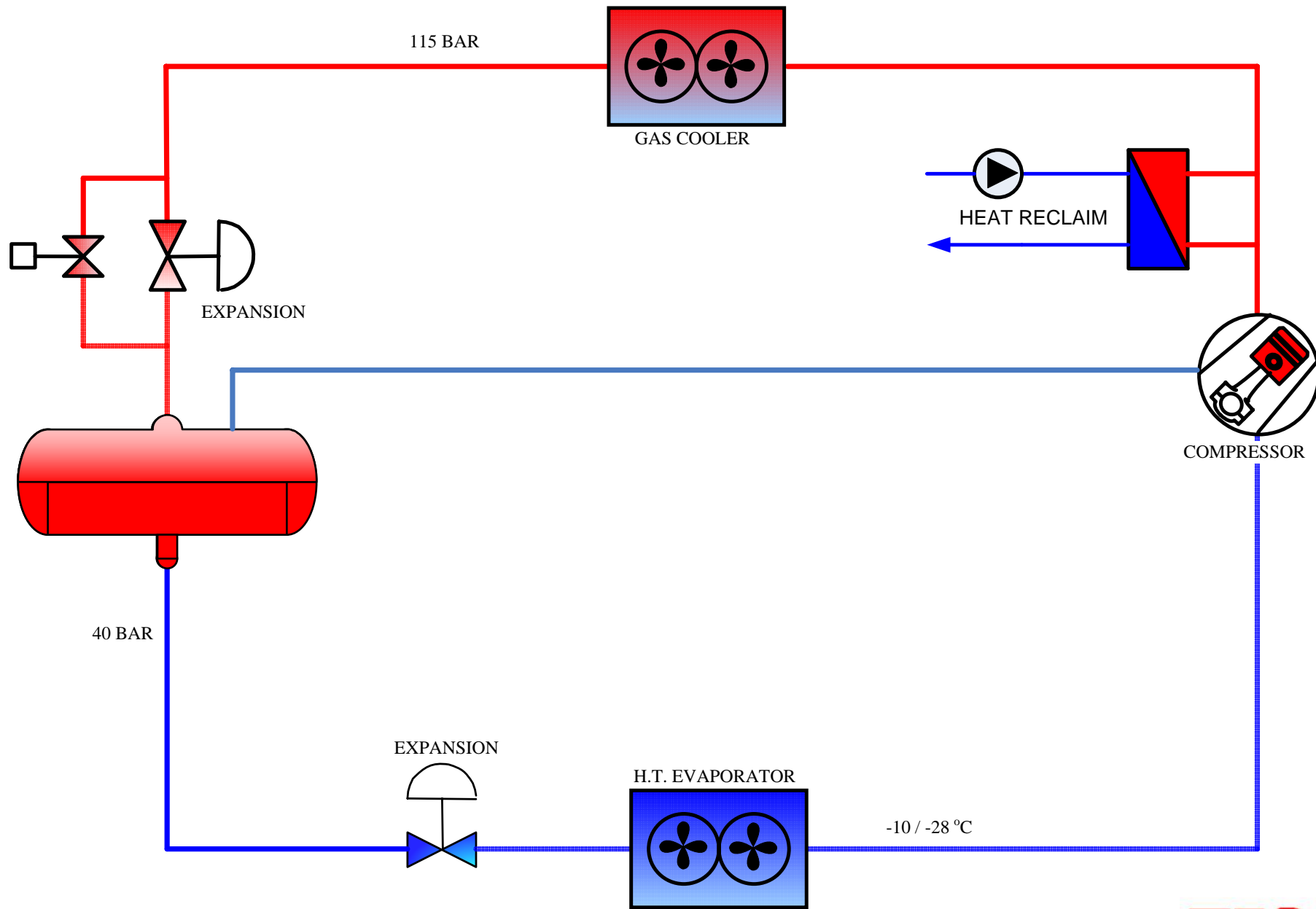

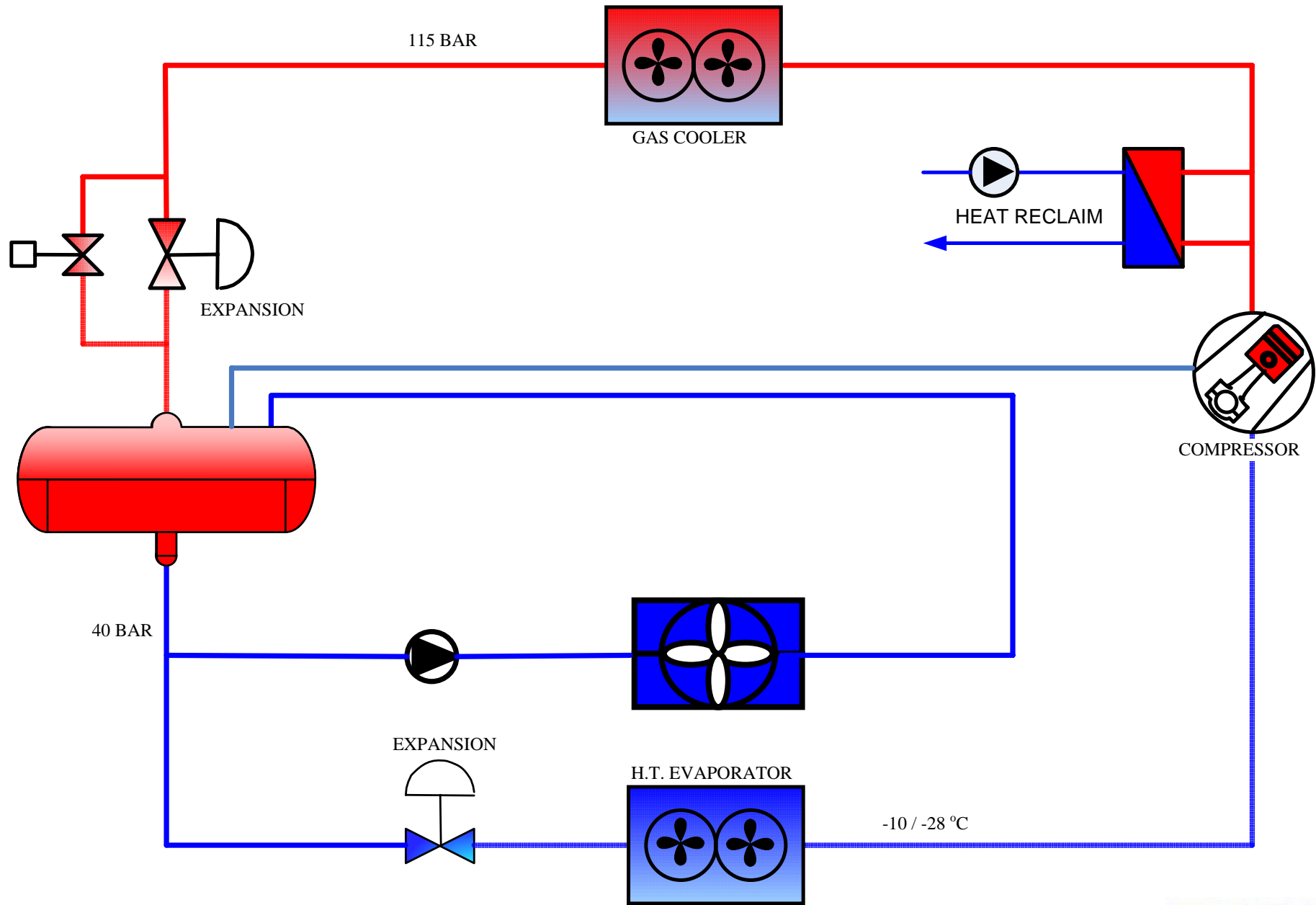

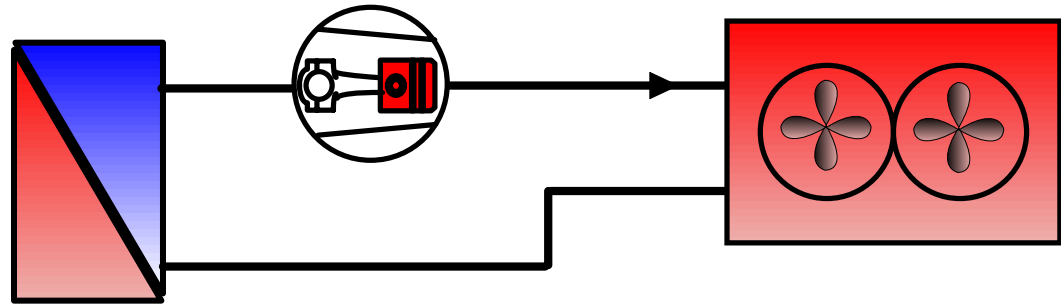

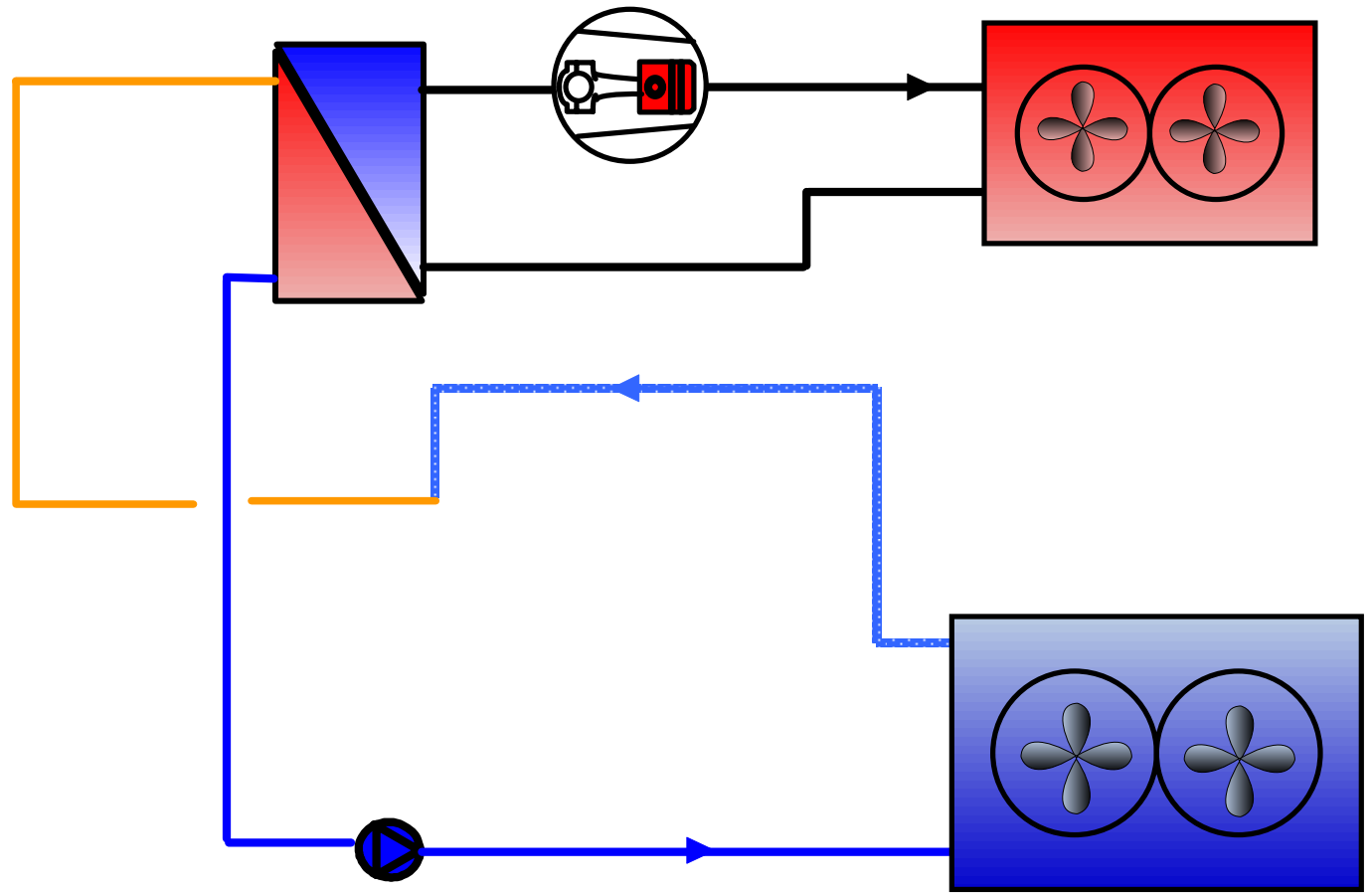

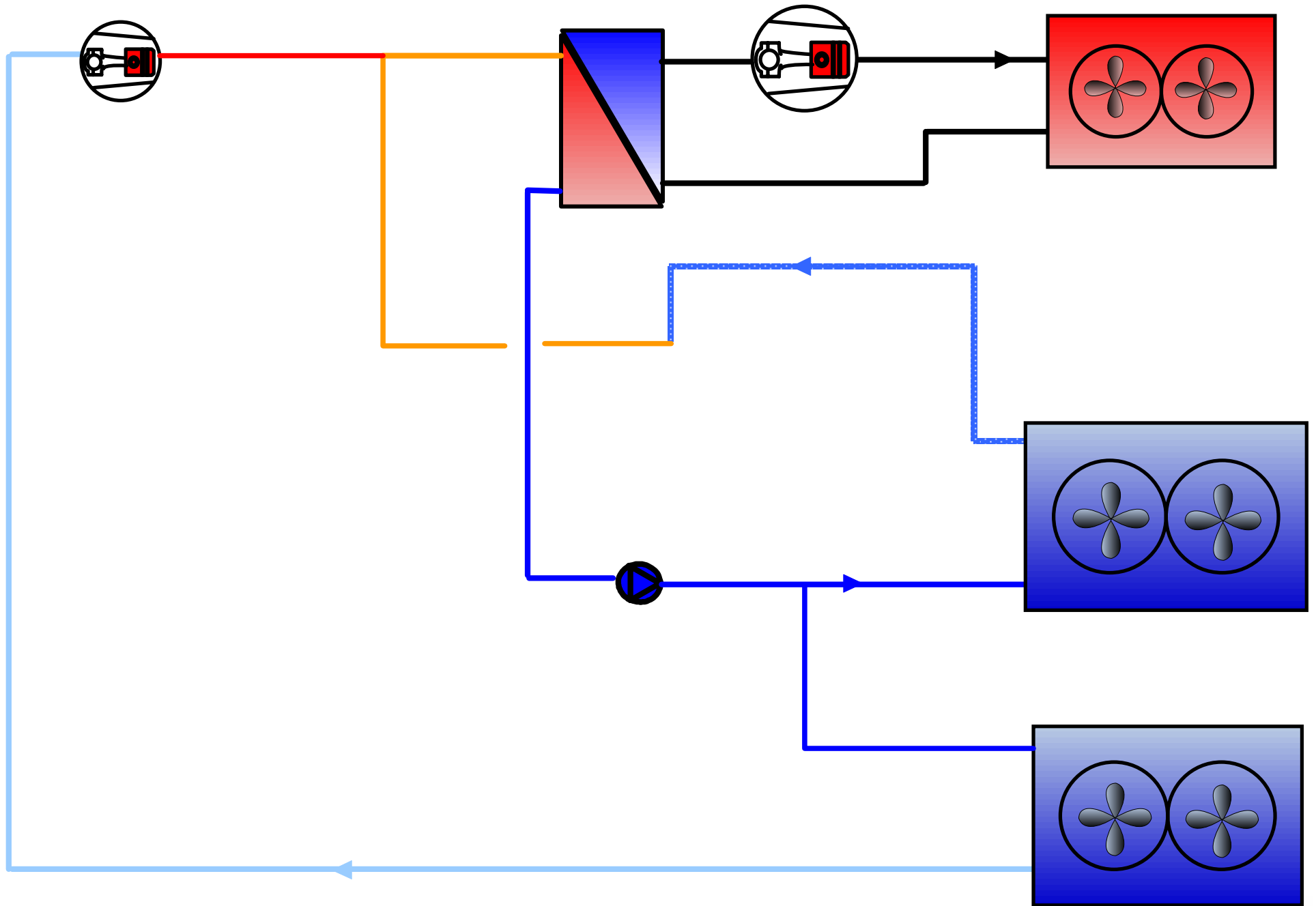

Future plans and how you can help

- We plan to develop modular solutions with the capability of suiting each store size and requirements
- We need experienced pack manufacturers
- We need experienced case manufacturers
- We need experienced service mechanics

Thank You for Listening
Go Raibh Mile Maith Agut Beith
Ag Eisteacht Liom