

Danish Society of Indoor Climate



Standard Test Method for the Determination of Particle Emission from Building Products

1st Edition
21st October 1997

Further information:

Danish Society of Indoor Climate
Danish Technological Institute
Building Technology
P.O. Box 141
DK-2630 Taastrup

Telephone: +45 72 20 23 25
Telefax: +45 72 20 23 30
E-mail: dsfi@teknologisk.dk
Web: www.dsic.org



List of Contents

1. Introduction	3
1.1 Scope	4
1.2 Purpose and Field of Application	4
1.3 Principle	5
1.4 Revision	5
2. Definitions and Explanation of Terms	6
3. Test Set-Up and Measuring Equipment	7
3.1 Test Set-Up	7
3.2 Documentation of the Test Set-Up	8
4. Accomplishment of the Measurements	9
4.1 Sampling and Handling of Test Specimens	9
4.2 Preparation of a Test Specimen	9
4.3 Standard Test Conditions	10
4.4 Sampling of Test Specimens	10
4.5 Methods of Analysis	11
4.5.1 Fluoroscopy	11
4.5.2 Gravimetric Method	11
5. Assessment of Results	12
5.1 Documentation of Results	12
5.2 Calculation of Test Result	12
5.2.1 Gravimetric Testing	12
5.2.2 Testing by Use of Fluoroscopy	12
5.3 Assessment according to Classes	13
6. Statement of Results	14
6.1 Test Report	14
7. Literature	15
8. Appendix	16

1. Introduction

The Standard Test Method for Particle Emission from Building Products was prepared with support from the National Agency for Enterprise and Housing. The present Standard Test Method was prepared from July 1995 to September 1997 by a task group consisting of:

Erik Ipsen, Danogips A/S
Svend Anker Jørgensen, Ecophon A/S
Hanne Dybro Juhl, Glasuld A/S
Kurt Madsen, L. Hammerich & Co. A/S
Peter A. Nielsen, the Danish Building and Urban Research
Thomas Schneider, National Institute of Occupational Health
Suhail A. Sethi, National Institute of Occupational Health
Flemming Egtoft Knudsen, Danish Technological Institute, Alice Møller, Danish Technological Institute
Morten Egedorf, Danish Technological Institute
Annelise Larsen, Danish Society of Indoor Climate

In addition all members of the Product Standard Group "Ceiling and wall systems" have been involved in connection with the first test series and the completion of the standard test method.

The Standard Test Method for Particle Emission from Building Products was subject to hearing in the period 1st May to 4th June 1997 by the following:

- The board of the Danish Society of Indoor Climate
- The Labelling License Committee of the Danish Indoor Climate Labelling
- Others (authorities, institutions, organisations, companies), who have so wished

The Standard Test Method for Particle Emission from Building Products was approved by the Danish Society of Indoor Climate on a board meeting on 21st October 1997.

This 1st edition of the Standard Test Method for Particle Emission from Building Products is valid until a 2nd edition is available.

The English translation of the present document was prepared in January 2004.

In the event of any discrepancies in the text arising from translation, the Danish text shall prevail.

1.1 Scope

This method description provides the frames for determination of particle emission from building products. The indoor climate labelling of a building product according to the General Labelling Criteria of the Danish Society of Indoor Climate requires testing for the emission carried out according to the Standard Test Method for determination of the Indoor-Relevant Time-Value by Chemical Analysis and Sensory Evaluation, 2nd Edition, 2003 [1].

When determining the indoor environmental properties of a product, the standard test methods in connection with the relevant product standards are used, which give the product specific guidelines. The requirements of the product standards take precedence over the requirements stated in the standard test method.

The present document describes the standard test method for quantification of the emission of particles from materials. There is no differentiation between the type and form of the particles including fibres.

In the product standards of the Danish Society of Indoor Climate additional requirements can be stated, if there is risk in an actual product standard area that the products could emit particles with potential comfort and health risk. These requirements could be a supplement to a possible legislation on the area.

The method is based on the Nordtest method NT Build 347: Ceiling Boards, mineral fibres: Emission [2]. The background material of the method is given in Bachmann and Nielsen, 1985 [3].

The scope of the testing is described in section 4.5 and the classification of the results is described in 5.3.

1.2 Purpose and Field of Application

The purpose of the method is to set a standard for the emission of particles, which eventually might cause irritation of skin, eyes, nose and upper airways.

By the method the particle emission is measured as sedimentary dust emitted from new, intact building products. Potential other properties relevant to the indoor environment are not considered. The method does not include evaluation of the particle emission in the building phase.

The building products, which can be tested according to the method, are panels for ceilings and walls, which when installed according to the guidelines of the supplier can form part of the ceiling system.

By the method the particle emission from the panels installed according to the supplier's recommended assembly system is tested.

Emission of particles measured at an early stage of the service life of a product gives no information about the emission of particles at long-term use and potential degradation of the material.

The method can only be used as a basis of labelling of a given product in case a product standard is available.

1.3 Principle

Test specimens are installed in a test set-up and vibrated with sound from a loudspeaker.

The test set-up is designed as a chamber and the test specimen constitutes the cover. At the bottom of the chamber two thoroughly cleaned glass plates are placed.

The particles emitted from the test specimen fall on to the glass plates. After some time the dust is collected from the glass plates by means of gel-tape. The area percentage is measured with an automatic fluorescent device cf. 4.5.1 and Appendix A. The weight of emitted particles per unit of surface is determined gravimetrically by vacuuming the entire bottom of the chamber cf. 4.5.2.

1.4 Revision

Changes are subject to adoption by the board of the Danish Society of Indoor Climate.

2. Definitions and Explanation of Terms

Area Percentage [%]

By area percentage is understood the percentage of the bottom area, which is covered by dust particles emitted from the tested panels.

During testing an emission of particles is expected. The particles will fall on to the bottom of the test chamber. The area percentage is measured by scattering light transmission of gel-tape taken as a contact print of the bottom of the box before and after exposure.

Detection Limit

The measurement methods used have a limited sensitivity. It is common to calculate the detection limit as an expression of the smallest emission, which can be measured with an acceptable certainty corresponding to 3 times the standard deviation.

Sedimentary Dust

By sedimentary dust is understood the amount of particles, which is able to settle at the bottom of the test chamber during the testing period including the time of at least 1 hour, in which the test set-up is left untouched after the vibration has ceased.

3. Test Set-Up and Measuring Equipment

3.1 Test Set-Up

The test set-up corresponds to the one described in NT Build 347 [2]. The design of the test set-up is based on practical experiences.

The test specimen is exposed to vibrations caused by pink noise induced to the test chamber from a loudspeaker. The level of vibration is measured by means of an accelerometer.

The level of vibration is kept constant throughout the testing and measurements are carried out linearly with time weighting "RMS-slow" on directly showing measurement equipment or "RMS" on integrating measuring equipment.

The test set-up should be equipped with equipment for regulation of air temperature and relative humidity. During the testing these parameters should be supervised. Test conditions should appear from a test journal.

The test chamber should have an interior surface, which neither emits particles nor gets statically charged and it should be easy to clean. The test chamber could be made of e.g. polished, stainless steel or of wood covered with a metal plate on the inside.

Test Chamber

Below is an example of a test chamber described.

The test set-up is a chamber with a basic area of 1.2 m x 1.2 m and a height of 0.6 m. The sides are made of 12 mm plywood. The chamber is double symmetrical and has two loudspeakers, two windows and four sliding doors. Inside it is covered with a 1 mm aluminium plate. Interior edges and corners are covered with aluminium foil, which makes the chamber airtight and cleaning friendly.

The windows are equipped with 6 mm glass. The sliding doors are inside covered with 1 mm steel plates, which decrease the frictional resistance between door and the inside aluminium covering. The loudspeakers are on the front covered with a 0.2 mm rubber membrane (cofferdam plate), which makes cleaning simple.

During the testing the test specimens constitute the cover of the chamber. The test specimens should be set up as close as possible to practical conditions according to the guidelines of the supplier.

A sketch of the test chamber in principle appears from figure 3.1.1. A sketch with indication of dimensions and a sketch of suspension appears from NT Build 347 [2].

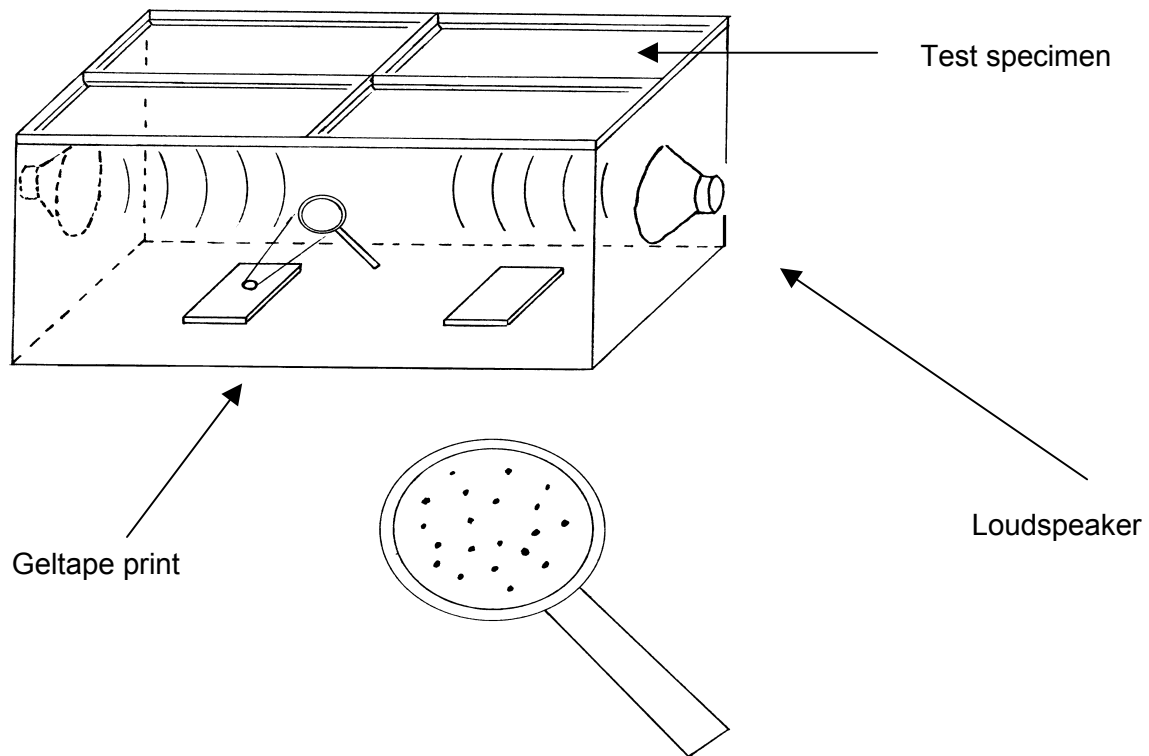

Figure 3.1.1 Test Chamber – sketch

Tone oscillator

Tone oscillator should be able to generate pink noise.

Pink noise is characterised by the sound energy being the same at all frequency bands from 20-20,000 Hz. With the equipment described the applied frequencies will be in the range from approx. 80 to 4,000 Hz.

Loudspeakers

The loudspeakers should be able to generate such a sound level that an acceleration level turns up as described in the standard test conditions (cf. 4.3) on the outside of the test set-up. The signal from the two loudspeakers should be in phase. E.g. a Celestion F1 2K-85 could be used as loudspeaker.

3.2 Documentation of the Test Set-Up

The laboratory carrying out the testing should document performance of the test set-up and the properties of the measuring equipment, and state control methods to ensure the quality of the result. Documentation and control methods should be according to a quality assurance system and should be accessible at the place of work.

In the standard test conditions requirements are set for air temperature, relative humidity and acceleration. The requirements are stated as a mean value and the maximum allowable deviation from the mean value.

The background level should be documented by blind measurements. A blind measurement is performed like a common measurement, but with a cover of plastic foil in stead of a test specimen.

4. Accomplishment of the Measurements

Testing should be carried out on a representative sample, which is mounted as prescribed by the supplier.

The frame with the test specimens is placed as a cover, and the test set-up is cleaned. The test set-up is left untouched for at least 1 hour prior to initiation of the vibration.

Two glass plates for sampling of analysis specimens c.f. 4.4 are placed through the doors in the sides. The vibration is initiated and is ongoing for 15 hours.

The test set-up is left untouched for at least 1 hour in order to let the particles settle. Then the doors are opened very carefully, in order not to create circulation of the air in the test set-up. After each measurement 6 prints with the same gel-tape is carried out on each glass plate in order to obtain 2 analysis specimens for double determination, then the entire bottom of the test chamber is vacuum-cleaned through a glass fibre filter.

4.1 Sampling and Handling of Test Specimens

At sampling the following should be recorded:

- Contact person of the company
- Number and size of test specimens
- Identification of the test specimen in relation to manufacture, e.g. manufacture week or manufacture no.
- Statement of criteria for sampling
- Relevant observations which might influence the test result

Reference is made to the potential requirements of the product standards.

4.2 Preparation of a Test Specimen

Below the general guidelines for preparation and conditioning of the test specimens are stated. Specific guidelines for different test specimens are stated in the product standards.

The preparation of test specimens to be tested depends on the building product.

The test specimens are sampled at random from a larger quantity delivered by the supplier. Test specimens are sampled corresponding to an area of 1.2 m x 1.2 m.

The test specimens are placed in a suspension system, which as far as possible is similar to the installation system normally prescribed by the supplier. As far as it is possible test specimens sized 0.6 x 0.6 m are used. The number of joints between the panels should be the same as in practice. Joints should be placed above the centre of the test chamber. See figure 4.2.1.

The test specimens should as far as possible remain their original form. If the test specimens are shaped, the edges should be treated according to the guidelines of the supplier.

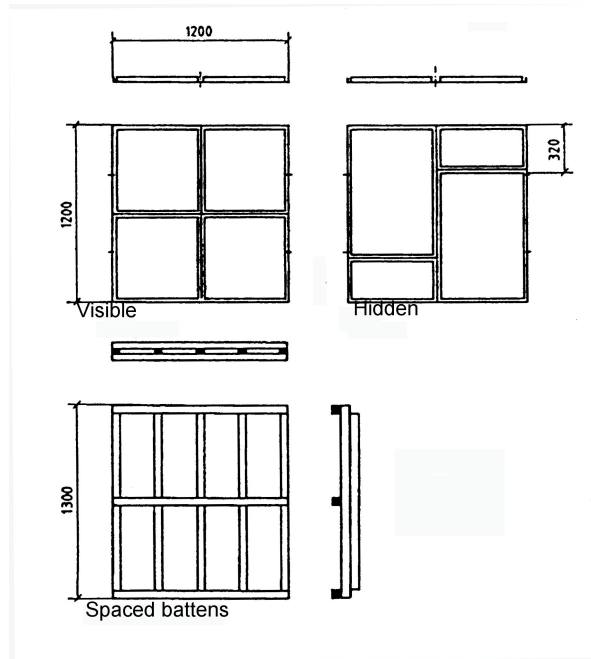

Figure 4.2.1 Examples of suspension of test specimens

Prior to testing the test specimens are conditioned at a constant temperature and relative humidity corresponding to the standard test conditions. The conditioning continues for minimum 24 hours. After conditioning the test specimens are placed in the suspension system. The test specimens should be handled carefully, so that they are not damaged prior to testing.

4.3 Standard Test Conditions

Air temperature	$23 \pm 2^\circ\text{C}$
Relative humidity	$50 \pm 5\%$
Acceleration	$2.4 \pm 0.2 \text{ m/s}^2$

The standard test conditions should be fulfilled simultaneously.

4.4 Sampling of Test Specimens

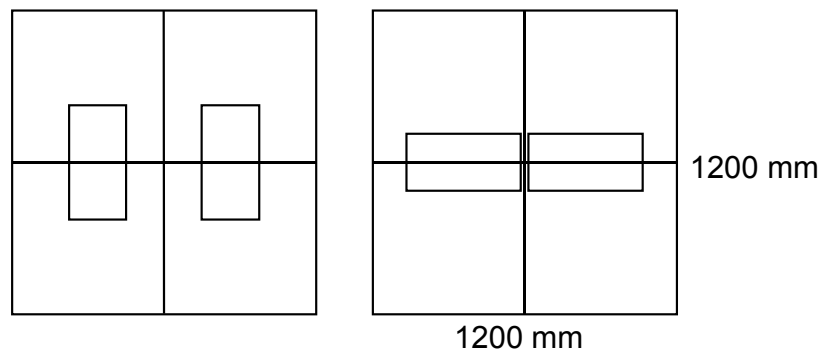

Figure 4.4.1 examples of placing of 2 glass plates. The placing is not critical, if only the plates are placed more than 150 mm from the edges of the chamber

2 glass plates are used as basis of the sampling of test specimens with gel-tape. The plates have the size 200 mm x 445 mm and should be clean and degreased. The plates should be placed loosely at the bottom of the test set-up as shown in figure 4.4.1. Print with gel-tape should be carried out with 6 prints evenly distributed on the glass plate, Appendix A.

4.5 Methods of Analysis

The testing is based on a gravimetric method.

To relate the test result to the cleaning quality (stated in area percentage) an informative measurement is, furthermore, carried out with an automatic fluoroscope.

In practice the measurement is carried out with an automatic fluoroscope before the gravimetric method.

4.5.1 Fluoroscopy

An informative measurement is carried through with a fluoroscope for automatic dust measurement, which measures the difference in turning down the light transmission of gel-tape before and after print as described in Appendix A.

4.5.2 Gravimetric Method

After measurement with a fluoroscope a gravimetric determination is carried out of the amount of emitted particles at the bottom of the test chamber by vacuuming the entire bottom of the test chamber, which is approx. 1.4 m² through a glass fibre filter, which detains particles larger than 0.7 µm. At weighing of the filters before and after exposure the particle emission is found in mg/m².

An industrial vacuum cleaner is used with a suction force of 40-50 l/sec and a vacuum of 20-23 kPa. A glass fibre filter (e.g. GF/G, Whatmann, 7.0 cm, 070) mounted in a holder is placed as a nozzle on the vacuum cleaner tube. The nozzle is cut with a sloping angle of 45°. The nozzle is lead systematically in the width of the nozzle above the bottom from one side of the box to the other, then the same procedure is carried out transversely, so that the bottom is vacuum cleaned twice all over the area.

After removal of the filter from the holders, potential dust on the nozzle should be brushed onto the filter and be included in the amount of dust. Long plastic gloves e.g. of PVC should be used to avoid contamination from textiles and the skin.

Filters should be conditioned at $23 \pm 2^\circ\text{C}$ and $50 \pm 5\%$ relative humidity for 4 hours before and after sampling e.g. by placing the filters in a conditioned weighing room or in the test chamber. Simultaneously with the filters at least 3 reference filters are weighed. The weight should have a standard deviation of 20 µg and a resolution of 10 µg.

5. Assessment of Results

5.1 Documentation of Results

For each individual testing the following should be described and documented:

- The sensibility of the method (detection limit) at standard test conditions should be documented by the laboratory
- Results documenting background values should be stated
- The test laboratory should document the standard deviation under the conditions in question

The accuracy of the method should not be stated as no other methods for measurement of particle emission exist, which could be used to control the results. The repetition and reproduction of the method are expectedly adequately good.

Blind measurements should be carried out like a normal measurement, but with a cover of plastic foil in stead of the test specimen. In this way the lower detection limit of the method is determined.

5.2 Calculation of Test Result

5.2.1 Gravimetric Testing

The particle emission is determined by weighing the filters before and after exposure, as the weight of the filters will be corrected for the difference from the blind test.

The difference in weight of the blind tests before and after sampling should be determined for each weighing series.

The detection limit is determined as 3 times the standard deviation of the blind tests exposed with plastic foil in the test chamber in stead of specimens. Blind tests are carried out before and after each testing series.

The result is stated as: particle emission calculated in mg dust per m² after 1, 3 and 15 hours respectively.

The mean value of the measurements after 3 and 15 hours is used for determination of the product in relation to the classification in 5.3

5.2.2 Testing by Use of Fluoroscopy

Additional measurements carried out by use of an automatic fluoroscope.

The result is stated as

- Dust percentage for glass plate 1 after 6 prints
- Dust percentage for glass plate 2 after 6 prints
- Mean value for dust percentage for the 2 glass plates
- 95% confidence interval for the mean value

5.3 Assessment according to Classes

The mean value for particle emission determined by gravimetric determination at 3 and 15 hours' measurements is used to assess the product.

The result is assessed in relation to the classification in 3 classes:

		High	>	2 mg/m ²
0.75 mg/m ²	<	Average	<=	2 mg/m ²
0.75 mg/m ²	>=	Low		

The determination is as an example low, if the mean value of the two measurements is lower than 0.75 mg dust per m².

The assessment of informative measurement of the dust percentage could eventually be carried out by comparison of cleaning quality, cf. Appendix B.

Labelling according to the criteria of the Danish Society of Indoor Climate is solely based on the result of gravimetric testing.

6. Statement of Results

Test reports should be equipped with a front page and the information as stated below.

6.1 Test Report

A test report should as minimum contain the following:

- The name and address of the test laboratory
- Unambiguous identification no. for the test report
- Name and address of the assignor
- Purpose of the testing

- Description and identification of the test specimen including:
 - Trade name
 - Production no. and production week
 - Construction of the test specimen
 - Information in writing as received including description of suspension system and e.g. formula, data sheets for the product and raw materials forming part of the product
- Date of receipt of the test specimen
- Method at sampling
- Conditioning of test specimens
- Date of start and completion of the testing
- Description of the suspension system and its geometry
- Description of test set-up including type and test conditions
- Description of other equipment
- Statement of deviations in relation to test descriptions
- Measurements, calculated results and assessments e.g. including:
 - Test conditions
 - Detection limit
 - Dispersion
 - Result (calculated result in [mg/m²], area percentage [%] and assessment according to classification: low, medium, high)
 - Special observations
- Uncertainty on test result including background values of the test chamber
- Date and signature of the person, who technically is responsible for the report
- Statement confirming whether or not the result only relates to the tested specimen

7. Literature

- 1 Danish Society of Indoor Climate, Standard Test Method for Determination of the Indoor-Relevant Time-Value by Chemical Analysis and Sensory Evaluation, 2nd Edition, 2003
- 2 Ceiling Boards, mineral fibres: Emission. Nordtest method, NT BUILD 347. Approved 1989-09
- 3 Bechmann, D. and P.A. Nielsen: Development of test method for determination of mineral fibre emission from ceiling boards. SBI, 1985 (internal publication in Danish).
- 4 Danish Building Research Institute. Indeklimahåndbogen (*The Indoor Climate Handbook*), SBI-anvisning 182, 1995.
- 5 Schneider, T., Petersen, O.H., Kildesø, J., Kloch, N.P., and Løbner, T.: Design and Calibration of a Simple Instrument for Measuring Dust on Surfaces in the Indoor Environment. *Indoor Air*, Vol. 6, No. 3, 204-210, 1996.
- 6 Schneider, T., Løbner, T., Petersen, O.H., Nilsen, S. and Nielsen, T.B.: Quality of cleaning quantified. *Build. Environ.* Vol. 29, 363_367, 1994.
- 7 Holst E. and Schneider T.: Fibre size characterization and size analysis using general and bivariate log-normal distribution. *J. Aerosol Sci.* Vol. 16, 407-413, 1985.

8. Appendix

Appendix A

Analysis of gel-tape print with automatic fluoroscopy

Appendix A Analysis of Gel-Tape Print with Automatic Fluoroscopy

At analysis with the automatic fluoroscope prints with gel-tape are used. The gel-tape in the dimension 2 cm x 7 cm and a roll should be used.

Print

1. Remove the protection tape from the topside of the gel-tape. It is the side equipped with a paper strip.
2. Take the specimen by placing the tape against the gel-side downwards to the glass surface. Hold the paper strip. By means of the roll the gel-tape is pressed onto the glass plate. To ensure a reproducible result, the roll should be rolled 3 times across the tape with an even pressure (1 kp).
3. The tape is removed
4. Totally 6 prints per gel-tape should be taken evenly distributed on the glass plate.
5. The tape is placed in the fluoroscopy. If it is required that the tape is controlled by microscopy, the protection tape is remounted.

Conduction of the Measurement

In the fluoroscope the gel-tape is used without protection tape.

1. Turn on the fluoroscope. When the display is ready, the gel-tape is placed in the gap in the measuring instrument with the gel-side turning away from the display. Press the button marked REF. The measuring instrument has now registered the blind value of the tape.
2. Expose the gel-tape as described.
3. The exposed gel-tape is replaced in the fluoroscope. The gel-tape should turn away from the display. Press the button marked %. The dust percentage of the surface, where the test has been sampled, can now be read directly on the display.

Calibration

The instrument is delivered pre-calibrated by the manufacturer. The calibration is carried out with special calibration slides with a known particle size and area percentage [5]. At start-up the built-in micro-processor controls light source, detector and electronic.

Detection Limit

Measurement of unexposed surfaces can give a certain measuring value. The standard deviation is 0.15 area percentage for glass surfaces. The detection limit calculated as 3 times the standard deviation therefore gives the result 0.5 area percentage. If 6 prints have been taken, the detection limit of the mean value is $\sqrt{6}=2.45$ times smaller – which is 0.2 area percentage.

For details see [5, 6, 7]